

Tandler
Hypoid
Servo Gearheads

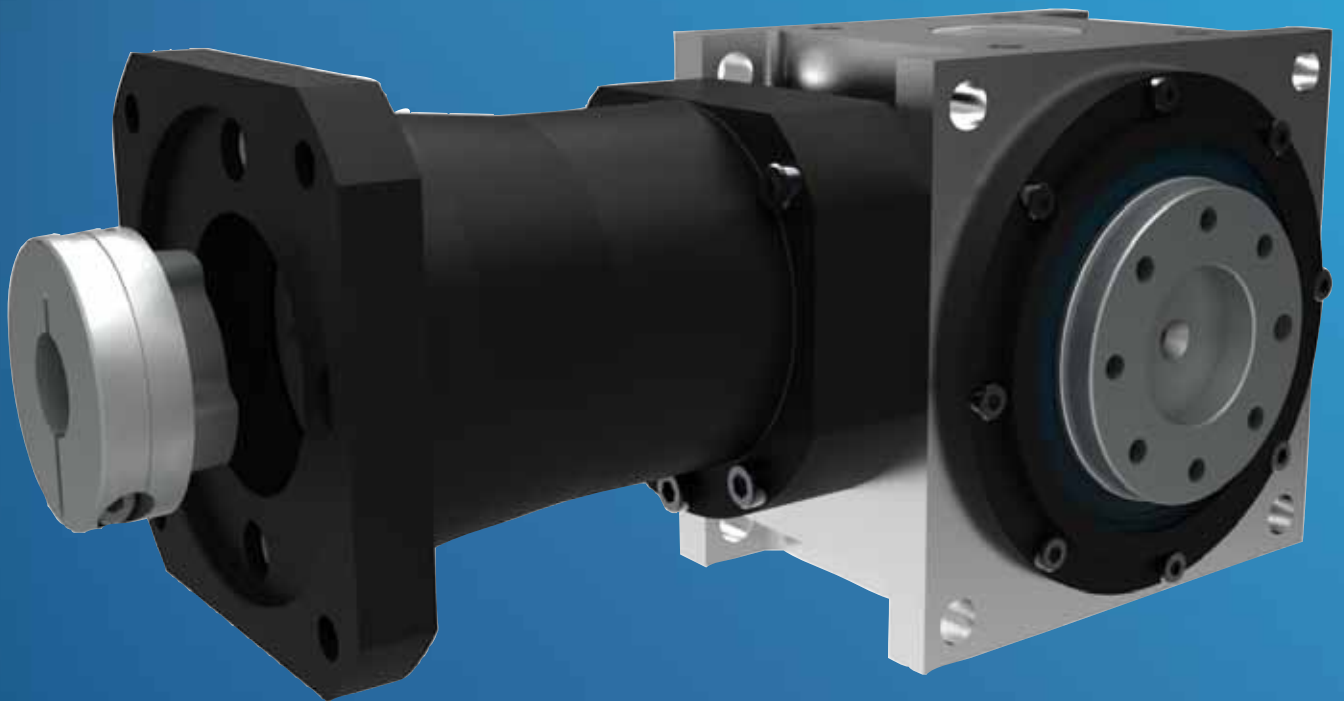

Available from
DIEQUA
Corporation

ServoFoxx® Hypoid Gearboxes

The new Hypoid gearbox from Tandler® offers the ultimate in performance and connection versatility for dynamic servo driven applications.



Benefits:

Low Backlash

Two levels of backlash optimize and enhance positioning accuracy and repeatability.

Flexible Motor Mount

A unique integral bellow coupling design compensates for misalignment, increasing performance .

Single Stage Ratios

Ratios from 5:1 to 15:1, depending on size, provide compact torque multiplication in a common size.

Output Shaft Versatility

Six output shaft configurations offer a wide variety of connection options for design versatility.

Accommodates All Servos

A modular flange and coupling system allows the integration of virtually all motors in the torque range.

Maintenance Free

Gearboxes are pre-filled with synthetic oil and are typically lubricated for life.



ServoFoxx® hypoid gearbox with robot flange HYP FS2 RF

Table of Contents:

Introduction	2
Variations and Ordering Example	3
Standard Version	4
Hollow Shaft with Keyway Version	6
Shrink Disc Version	8
Rotary Output Flange Version	10
Technical Data	14
Mounting Instructions	15

Gearbox Variants:



ServoFoxy® hypoid gearboxes HYP FS2 standard version
see page 4



ServoFoxy® hypoid gearboxes with hollow shaft HYP FS2 HW
see page 6



ServoFoxy® hypoid gearboxes with hollow shaft and shrink disc HYP FS2 HWS
see page 8



ServoFoxy® hypoid gearboxes with robot flange RF
see page 10



ServoFoxy® hypoid gearboxes with robot flange and hollow shaft HYP FS2 RF HW
see page 12

Ordering Example:

$\frac{\text{HYPFS2}}{\text{Model}}$ - $\frac{170}{\text{Size}}$ - $\frac{10:1}{\text{Ratio}}$ - $\frac{\text{I}}{\text{Arrangement}}$ - $\frac{\text{P}}{\text{w/Key}}$
 (std. version)

Note: Motor dimensions are required with your order.

ServoFoxx® Hypoid Gearboxes HYP FS2 Standard Version

The new TANDLER hypoid gearboxes are supplied with a plain output shaft as standard. A key on the output shaft can be supplied as a no-cost option. Due to the single-stage design, (ratios up to 15:1), very low backlash and transmission error is achievable. On the ServoFoxx® hypoid the input is via a flange and two-part coupling - suitable for virtually any servo motor.



Ratios:

5:1 to 15:1
depending on size.

Backlash:

Standard < 6 arc minutes
Reduced < 3 arc minutes

Gearbox Weight (approx):

Size	kg
90	4.5
115	8
140	13.5
170	23.5
192	32.5
215	47
240	70
260	90.5

Gear Arrangement:

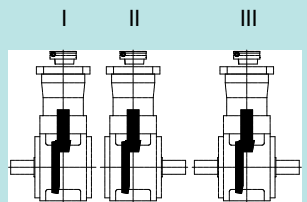

When ordering, specify mounting position and servo motor dimensions.

For additional technical specs and motor mounting, see pages 14-15

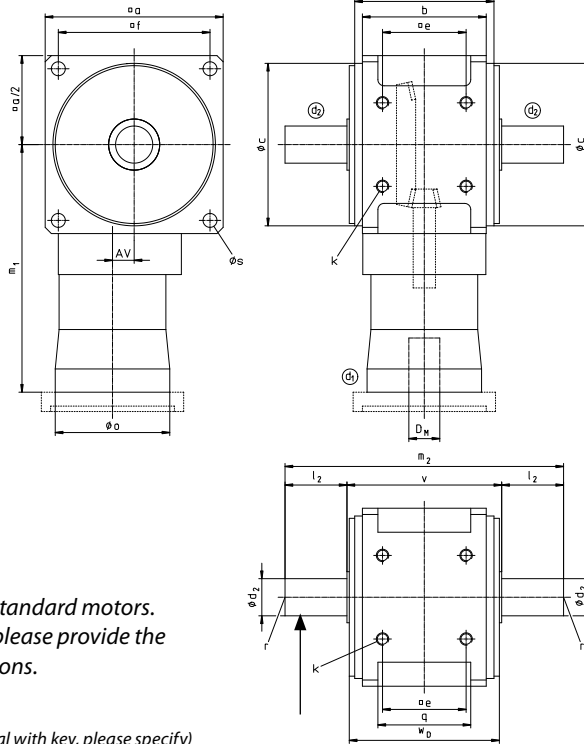

Suitable for all standard motors.
In your inquiry please provide the mating dimensions.

without key (optional with key, please specify)

dimensions [mm]

gearbox size	a	b	Øc _{g6}	D _M	e	f	k depth = 1.5 · k	m ₁	Øo	q	Øs	w	w _D	AV	Ø d _{2k6}	l ₂	m ₂	r DIN 332- D	v	key DIN 6885/1 d ₂ (optional)
HYP FS2 90	90	60	89	8-16	44	78	M6	127.5	59	44	7	79	87	9	20	35	160	M6	90	6 x 6
HYP FS2 115	115	80	105	8-24	54	98	M8	160	74	60	9	90	97	14	24	40	180	M8	100	8 x 7
HYP FS2 140	140	100	125	11-28	66	118	M10	177	93	78	11	109	116	18	32	50	220	M12	120	10 x 8
HYP FS2 170	170	120	150	14-32	80	144	M12	214	115	94	13.5	128	136	23	40	60	260	M16	140	12 x 8
HYP FS2 192	192	138	173	14-32	95	164	M12	238.5	115	110	13.5	151	158	27	48	75	312	M16	162	14 x 9
HYP FS2 215	215	146	195	19-42	104	182	M16	264.5	136	116	17.5	158	166	32	55	90	350	M20	170	16 x 10
HYP FS2 240	240	166	225	19-55	120	206	M16	343	160	134	17.5	178	186	38	60	100	390	M20	190	18 x 11
HYP FS2 260	260	196	245	19-55	140	224	M16	348	160	162	17.5	208	216	42	70	110	440	M20	220	20 x 12

performance data HYP FS2						
gearbox size	ratio i	rated torque M_{2nenn} [Nm] 200 min ⁻¹	rated torque M_{2nenn} [Nm] 1500 min ⁻¹	rated torque M_{2nenn} [Nm] 3000 min ⁻¹	max. torque M_{2max} [Nm]	inertia J [10 ⁻⁵ kgm ²]
HYP FS2 90	5:1	50	39	31	75	5.1
HYP FS2 115	5:1	75	75	66	98	13.1
HYP FS2 140	5:1	146	146	115	205	36.7
HYP FS2 170	5:1	290	206	164	406	85.7
HYP FS2 192	5:1	325	325	289	487	136.7
HYP FS2 215	5:1	726	519	391	963	347.7
HYP FS2 240	5:1	1100	661	519	1543	1047.6
HYP FS2 260	5:1	1510	859	682	2118	1401.7
HYP FS2 90	8:1	49	39	31	61	3.7
HYP FS2 115	8:1	85	80	64	120	9.8
HYP FS2 140	8:1	160	136	108	220	28.4
HYP FS2 170	8:1	292	201	160	411	64.5
HYP FS2 192	8:1	422	313	254	592	93.6
HYP FS2 215	8:1	677	464	343	950	250.3
HYP FS2 240	8:1	1020	593	448	1445	871.6
HYP FS2 260	8:1	1350	753	557	2113	1041.7
HYP FS2 90	10:1	36	36	34	63	3.4
HYP FS2 115	10:1	75	75	63	104	9
HYP FS2 140	10:1	147	125	99	206	26.2
HYP FS2 170	10:1	245	189	150	344	59.4
HYP FS2 192	10:1	355	306	247	539	84.7
HYP FS2 215	10:1	612	437	323	859	230.5
HYP FS2 240	10:1	908	582	456	1433	831
HYP FS2 260	10:1	1330	702	520	1867	961.4
HYP FS2 115	12:1	67	67	62	94	8.6
HYP FS2 140	12:1	116	116	99	163	25
HYP FS2 170	12:1	211	196	156	296	57
HYP FS2 192	12:1	322	307	241	452	78
HYP FS2 215	12:1	504	462	373	706	219.6
HYP FS2 240	12:1	783	595	439	1098	809.2
HYP FS2 260	12:1	1063	741	549	1491	915.9
HYP FS2 140	15:1	107	107	102	146	24.1
HYP FS2 170	15:1	177	177	159	249	55
HYP FS2 192	15:1	294	294	232	417	73
HYP FS2 215	15:1	517	376	279	726	210.2
HYP FS2 240	15:1	711	561	415	997	791.4
HYP FS2 260	15:1	1032	681	504	1447	880.3

ServoFoxx® Hypoid Gearboxes HYP FS2 with hollow shaft HW

In the HW version, the output side is configured as a hardened and ground hollow shaft with keyway. So a simple connection via shaft and key is feasible. The high surface hardness of the shaft prevents premature fretting of the positive connection.



Ratios:

5:1 to 15:1
depending on size.

Backlash:

Standard < 6 arc minutes
Reduced < 3 arc minutes

Gearbox Weight (approx):

Size	kg
90	4
115	7.5
140	12
170	21
192	29
215	40.5
240	60.5
260	77

Gear Arrangement:

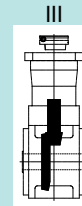

When ordering, specify mounting position and servo motor dimensions.

For additional technical specs and motor mounting, see pages 14-15

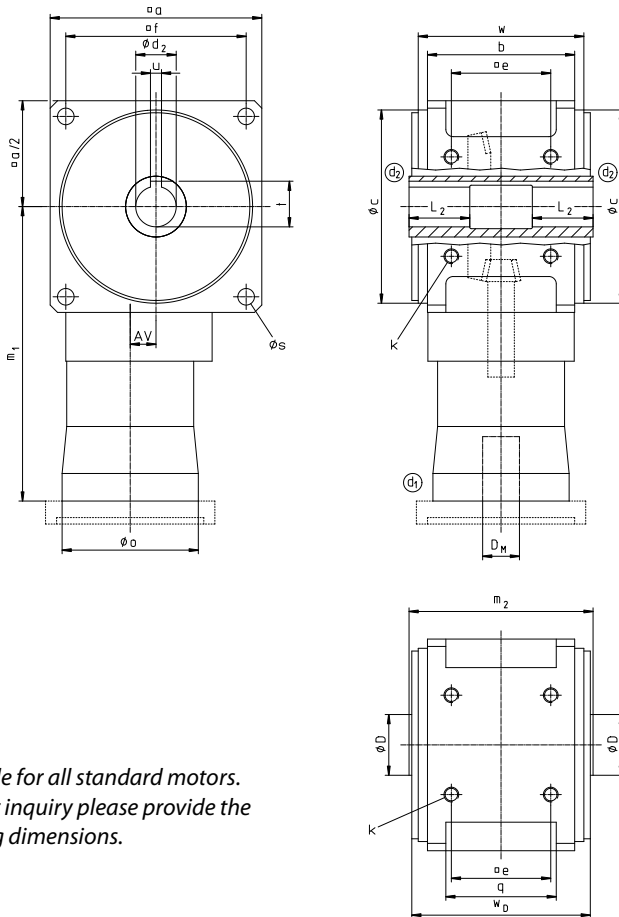

Suitable for all standard motors.
In your inquiry please provide the mating dimensions.

dimensions [mm]

gearbox size	a	b	$\varnothing_{c_{g6}}$	D_M	e	f	k depth =1.5·k	m_1	\varnothing_o	q	\varnothing_s	w	w_D	AV	$\varnothing_{d_2}^{H7}$	L_2	\varnothing_D	m_2	t	u^{J9}
HYP FS2 HW 90	90	60	89	8-16	44	78	M6	127.5	59	44	7	79	87	9	16	24	28	90	18.3	5
HYP FS2 HW 115	115	80	105	8-24	54	98	M8	160	74	60	9	90	97	14	22	33	33	100	24.8	6
HYP FS2 HW 140	140	100	125	11-28	66	118	M10	177	93	78	11	109	116	18	25	38	40	120	28.3	8
HYP FS2 HW 170	170	120	150	14-32	80	144	M12	214	115	94	13.5	128	136	23	35	55	55	140	38.3	10
HYP FS2 HW 192	192	138	173	14-32	95	164	M12	238.5	115	110	13.5	151	158	27	42	63	65	162	45.3	12
HYP FS2 HW 215	215	146	195	19-42	104	182	M16	264.5	136	116	17.5	158	166	32	55	80	80	170	59.3	16
HYP FS2 HW 240	240	166	225	19-55	120	206	M16	343	160	134	17.5	178	186	38	60	80	90	190	64.4	18
HYP FS2 HW 260	260	196	245	19-55	140	224	M16	348	160	162	17.5	208	216	42	70	90	100	220	74.9	20

performance data HYP FS2 HW						
gearbox size	ratio i	rated torque M_{2nenn} [Nm] 200 min ⁻¹	rated torque M_{2nenn} [Nm] 1500 min ⁻¹	rated torque M_{2nenn} [Nm] 3000 min ⁻¹	max. torque M_{2max} [Nm]	inertia J [10 ⁻⁵ kgm ²]
HYP FS2 HW 90	5:1	50	39	31	75	5.1
HYP FS2 HW 115	5:1	75	75	66	98	12.9
HYP FS2 HW 140	5:1	146	146	115	205	36.2
HYP FS2 HW 170	5:1	290	206	164	406	83.9
HYP FS2 HW 192	5:1	325	325	289	487	132.5
HYP FS2 HW 215	5:1	726	519	391	963	337.5
HYP FS2 HW 240	5:1	1100	661	519	1543	1031.5
HYP FS2 HW 260	5:1	1510	859	682	2118	1368
HYP FS2 HW 90	8:1	49	39	31	61	3.7
HYP FS2 HW 115	8:1	85	80	64	120	9.7
HYP FS2 HW 140	8:1	160	136	108	220	28.2
HYP FS2 HW 170	8:1	292	201	160	411	63.8
HYP FS2 HW 192	8:1	422	313	254	592	92
HYP FS2 HW 215	8:1	677	464	343	950	246.3
HYP FS2 HW 240	8:1	1020	593	448	1445	865.3
HYP FS2 HW 260	8:1	1350	753	557	2113	1028.6
HYP FS2 HW 90	10:1	36	36	34	63	3.4
HYP FS2 HW 115	10:1	75	75	63	104	9
HYP FS2 HW 140	10:1	147	125	99	206	26
HYP FS2 HW 170	10:1	245	189	150	344	58.9
HYP FS2 HW 192	10:1	355	306	247	539	83.7
HYP FS2 HW 215	10:1	612	437	323	859	227.9
HYP FS2 HW 240	10:1	908	582	456	1433	827
HYP FS2 HW 260	10:1	1330	702	520	1867	952.9
HYP FS2 HW 115	12:1	67	67	62	94	8.6
HYP FS2 HW 140	12:1	116	116	99	163	24.9
HYP FS2 HW 170	12:1	211	196	156	296	56.7
HYP FS2 HW 192	12:1	322	307	241	452	77.2
HYP FS2 HW 215	12:1	504	462	373	706	217.8
HYP FS2 HW 240	12:1	783	595	439	1098	806.4
HYP FS2 HW 260	12:1	1063	741	549	1491	910
HYP FS2 HW 140	15:1	107	107	102	146	24.1
HYP FS2 HW 170	15:1	177	177	159	249	54.8
HYP FS2 HW 192	15:1	294	294	232	417	72.5
HYP FS2 HW 215	15:1	517	376	279	726	209.1
HYP FS2 HW 240	15:1	711	561	415	997	789.6
HYP FS2 HW 260	15:1	1032	681	504	1447	876.6

ServoFoxx® Hypoid Gearboxes HYP FS2 with hollow shaft and shrink disc HWS

The HWS design, with a ground hollow shaft and shrink disc has a strong, positive connection. This is completely free of play and resistant to shock or reversing loads.



Ratios:

5:1 to 15:1
depending on size.

Backlash:

Standard < 6 arc minutes
Reduced < 3 arc minutes

Gearbox Weight (approx):

Size	kg
90	4.5
115	8
140	12.5
170	22
192	29
215	42.5
240	64
260	80

Gear Arrangement:

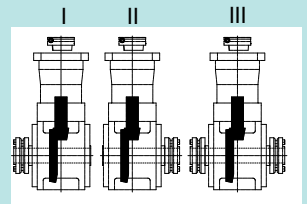

With gear arrangement III (RA III) only one shrink disc included as standard.

When ordering, specify mounting position and servo motor dimensions.

For additional technical specs and motor mounting, see pages 14-15

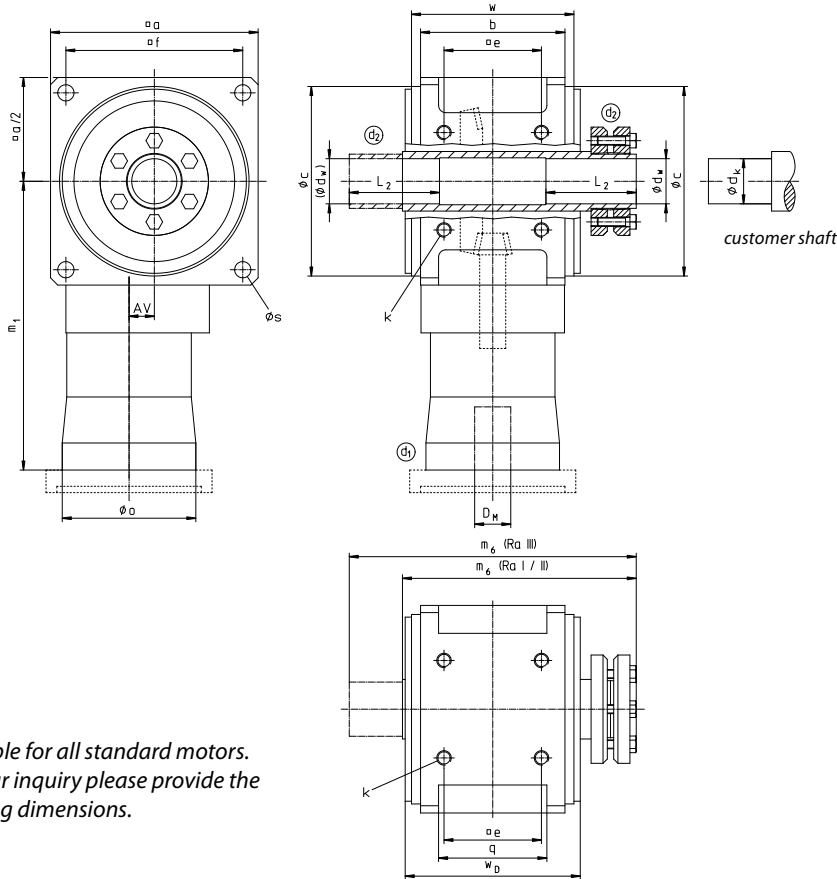

Suitable for all standard motors.
In your inquiry please provide the mating dimensions.

dimensions [mm]

gearbox size	a	b	Øcg6	DM	e	f	k depth =1.5•k	m1	Øo	q	Øs	w	wD	AV	Ø dw H6	L2	m6 RA I, II	m6 RA III	Ø dk customershaft
HYP FS2 HWS 90	90	60	89	8-16	44	78	M6	127.5	59	44	7	79	87	9	20	40	116.5	143	20 h6
HYP FS2 HWS 115	115	80	105	8-24	54	98	M8	160	74	60	9	90	97	14	25	50	129.5	159	25 h6
HYP FS2 HWS 140	140	100	125	11-28	66	118	M10	177	93	78	11	109	116	18	30	60	153	186	30 h6
HYP FS2 HWS 170	170	120	150	14-32	80	144	M12	214	115	94	13.5	128	136	23	40	80	177	214	40 h6
HYP FS2 HWS 192	192	138	173	14-32	95	164	M12	238.5	115	110	13.5	151	158	27	48	96	202	242	48 h6
HYP FS2 HWS 215	215	146	195	19-42	104	182	M16	264.5	136	116	17.5	158	166	32	55	110	212	254	55 g6
HYP FS2 HWS 240	240	166	225	19-55	120	206	M16	343	160	134	17.5	178	186	38	60	120	234	278	60 g6
HYP FS2 HWS 260	260	196	245	19-55	140	224	M16	348	160	162	17.5	208	216	42	70	140	269	318	70 g6

performance data HYP FS2 HWS						
gearbox size	ratio i	rated torque M_{2nenn} [Nm] 200 min ⁻¹	rated torque M_{2nenn} [Nm] 1500 min ⁻¹	rated torque M_{2nenn} [Nm] 3000 min ⁻¹	max. torque M_{2max} [Nm]	inertia J [10 ⁻⁵ kgm ²]
HYP FS2 HWS 90	5:1	50	39	31	75	5.4
HYP FS2 HWS 115	5:1	75	75	66	98	13.6
HYP FS2 HWS 140	5:1	146	146	115	205	37.7
HYP FS2 HWS 170	5:1	290	206	164	406	88.3
HYP FS2 HWS 192	5:1	325	325	289	487	138.8
HYP FS2 HWS 215	5:1	726	519	391	963	352
HYP FS2 HWS 240	5:1	1100	661	519	1543	1062.2
HYP FS2 HWS 260	5:1	1510	859	682	2118	1407.9
HYP FS2 HWS 90	8:1	49	39	31	61	3.8
HYP FS2 HWS 115	8:1	85	80	64	120	10
HYP FS2 HWS 140	8:1	160	136	108	220	28.8
HYP FS2 HWS 170	8:1	292	201	160	411	65.6
HYP FS2 HWS 192	8:1	422	313	254	592	94.4
HYP FS2 HWS 215	8:1	677	464	343	950	252
HYP FS2 HWS 240	8:1	1020	593	448	1445	877.3
HYP FS2 HWS 260	8:1	1350	753	557	2113	1044.1
HYP FS2 HWS 90	10:1	36	36	34	63	3.4
HYP FS2 HWS 115	10:1	75	75	63	104	9.2
HYP FS2 HWS 140	10:1	147	125	99	206	26.4
HYP FS2 HWS 170	10:1	245	189	150	344	60.1
HYP FS2 HWS 192	10:1	355	306	247	539	85.2
HYP FS2 HWS 215	10:1	612	437	323	859	231.5
HYP FS2 HWS 240	10:1	908	582	456	1433	834.7
HYP FS2 HWS 260	10:1	1330	702	520	1867	962.9
HYP FS2 HWS 115	12:1	67	67	62	94	8.7
HYP FS2 HWS 140	12:1	116	116	99	163	25.1
HYP FS2 HWS 170	12:1	211	196	156	296	57.5
HYP FS2 HWS 192	12:1	322	307	241	452	78.3
HYP FS2 HWS 215	12:1	504	462	373	706	220.3
HYP FS2 HWS 240	12:1	783	595	439	1098	811.8
HYP FS2 HWS 260	12:1	1063	741	549	1491	917
HYP FS2 HWS 140	15:1	107	107	102	146	24.3
HYP FS2 HWS 170	15:1	177	177	159	249	55.3
HYP FS2 HWS 192	15:1	294	294	232	417	73.2
HYP FS2 HWS 215	15:1	517	376	279	726	210.7
HYP FS2 HWS 240	15:1	711	561	415	997	793
HYP FS2 HWS 260	15:1	1032	681	504	1447	881

ServoFoxx® Hypoid gearboxes HYP FS2 with robotic flange RF

With the RF-design, tools for industrial robot applications in accordance with EN ISO 9409-1 can be mounted on to the robot flange. Here we can offer the ServoFoxx® hypoid as an alternative to conventional planetary gearboxes, because the right angle output saves important installation space.



Ratios:

5:1 to 15:1
depending on size.

Backlash:

Standard < 6 arc minutes
Reduced < 3 arc minutes

Gearbox Weight (approx):

Size	kg
90	4.5
115	8
140	13
170	23
192	31.5
215	45
240	66
260	86

Gear Arrangement:

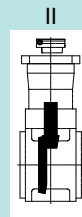

When ordering, specify mounting position and servo motor dimensions.

For additional technical specs and motor mounting, see pages 14-15

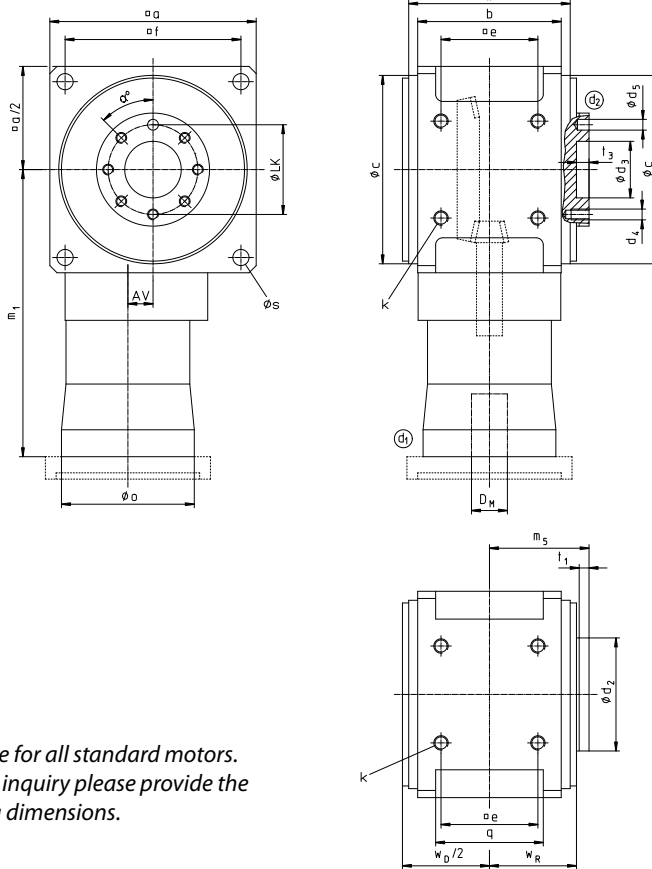

Suitable for all standard motors.
In your inquiry please provide the mating dimensions.

dimensions [mm]

gearbox size	a	b	Øc _{g6}	D _M	e	f	k depth = 1.5 · k	m ₁	Øo	q	Øs	w	w _D	w _R	AV
HYP FS2 RF 90	90	60	89	8-16	44	78	M6	127.5	59	44	7	79	87	43.5	9
HYP FS2 RF 115	115	80	105	8-24	54	98	M8	160	74	60	9	90	97	48.5	14
HYP FS2 RF 140	140	100	125	11-28	66	118	M10	177	93	78	11	109	116	58	18
HYP FS2 RF 170	170	120	150	14-32	80	144	M12	214	115	94	13.5	128	136	70.5	23
HYP FS2 RF 192	192	138	173	14-32	95	164	M12	238.5	115	110	13.5	151	158	79	27
HYP FS2 RF 215	215	146	195	19-42	104	182	M16	264.5	136	116	17.5	158	166	83	32
HYP FS2 RF 240	240	166	225	19-55	120	206	M16	343	160	134	17.5	178	186	93	38
HYP FS2 RF 260	260	196	245	19-55	140	224	M16	348	160	162	17.5	208	216	109.5	42

performance data HYP FS2 RF						
gearbox size	ratio <i>i</i>	rated torque M_{2nenn} [Nm] 200 min ⁻¹	rated torque M_{2nenn} [Nm] 1500 min ⁻¹	rated torque M_{2nenn} [Nm] 3000 min ⁻¹	max. torque M_{2max} [Nm]	inertia J [10 ⁻⁵ kgm ²]
HYP FS2 RF 90	5:1	50	39	31	75	5.3
HYP FS2 RF 115	5:1	75	75	66	98	13.8
HYP FS2 RF 140	5:1	146	146	115	205	39
HYP FS2 RF 170	5:1	290	206	164	406	90.6
HYP FS2 RF 192	5:1	325	325	289	487	142.1
HYP FS2 RF 215	5:1	726	519	391	963	365.2
HYP FS2 RF 240	5:1	1100	661	519	1543	1060.3
HYP FS2 RF 260	5:1	1510	859	682	2118	1463.9
HYP FS2 RF 90	8:1	49	39	31	61	3.8
HYP FS2 RF 115	8:1	85	80	64	120	10
HYP FS2 RF 140	8:1	160	136	108	220	29.3
HYP FS2 RF 170	8:1	292	201	160	411	66.4
HYP FS2 RF 192	8:1	422	313	254	592	95.8
HYP FS2 RF 215	8:1	677	464	343	950	257.1
HYP FS2 RF 240	8:1	1020	593	448	1445	876.5
HYP FS2 RF 260	8:1	1350	753	557	2113	1066
HYP FS2 RF 90	10:1	36	36	34	63	3.4
HYP FS2 RF 115	10:1	75	75	63	104	9.2
HYP FS2 RF 140	10:1	147	125	99	206	26.7
HYP FS2 RF 170	10:1	245	189	150	344	60.6
HYP FS2 RF 192	10:1	355	306	247	539	86.1
HYP FS2 RF 215	10:1	612	437	323	859	234.8
HYP FS2 RF 240	10:1	908	582	456	1433	834.2
HYP FS2 RF 260	10:1	1330	702	520	1867	976.9
HYP FS2 RF 115	12:1	67	67	62	94	8.8
HYP FS2 RF 140	12:1	116	116	99	163	25.4
HYP FS2 RF 170	12:1	211	196	156	296	57.9
HYP FS2 RF 192	12:1	322	307	241	452	78.9
HYP FS2 RF 215	12:1	504	462	373	706	222.6
HYP FS2 RF 240	12:1	783	595	439	1098	811.4
HYP FS2 RF 260	12:1	1063	741	549	1491	926.7
HYP FS2 RF 140	15:1	107	107	102	146	24.4
HYP FS2 RF 170	15:1	177	177	159	249	55.6
HYP FS2 RF 192	15:1	294	294	232	417	73.6
HYP FS2 RF 215	15:1	517	376	279	726	212.2
HYP FS2 RF 240	15:1	711	561	415	997	792.8
HYP FS2 RF 260	15:1	1032	681	504	1447	887.2

$\varnothing LK$	$\varnothing d_{2h8}$	$\varnothing d_3^{H7}$	d_4	number of tapped holes (d_4)	$\varnothing d_5^{H7}$ locating pin	m_5	t_1	t_3	α	gearbox size
40	50	25	M6	7	6	50.5	6	8	45°	HYP FS2 RF 90
50	63	31.5	M6	7	6	55.5	6	7	45°	HYP FS2 RF 115
63	80	40	M6	7	6	65	6	7	45°	HYP FS2 RF 140
80	100	50	M8	11	8	80.5	9	8.5	30°	HYP FS2 RF 170
80	100	50	M8	11	8	96.5	16	8.5	30°	HYP FS2 RF 192
100	125	63	M8	11	8	100.5	16	8.5	30°	HYP FS2 RF 215
100	125	63	M8	11	8	115	20	8.5	30°	HYP FS2 RF 240
125	160	80	M10	11	10	132.5	20	8.5	30°	HYP FS2 RF 260

ServoFoxx® Hypoid gearboxes HYP FS2 with robotic flange and hollow shaft RF HW

RF HW is our expansion of the robot flange according EN ISO 9409-1 with a hollow shaft to enable supply lines, cables or hoses to pass through the gearbox. This cannot be done with a conventional planetary gearhead due to the internal coaxial structure.



Ratios:

5:1 to 15:1
depending on size.

Backlash:

Standard < 6 arc minutes
Reduced < 3 arc minutes

Gearbox Weight (approx):

Size	kg
90	4.5
115	8
140	13
170	23
192	31.5
215	45
240	66
260	86

Gear Arrangement:

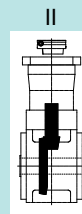

When ordering, specify mounting position and servo motor dimensions.

For additional technical specs and motor mounting, see pages 14-15

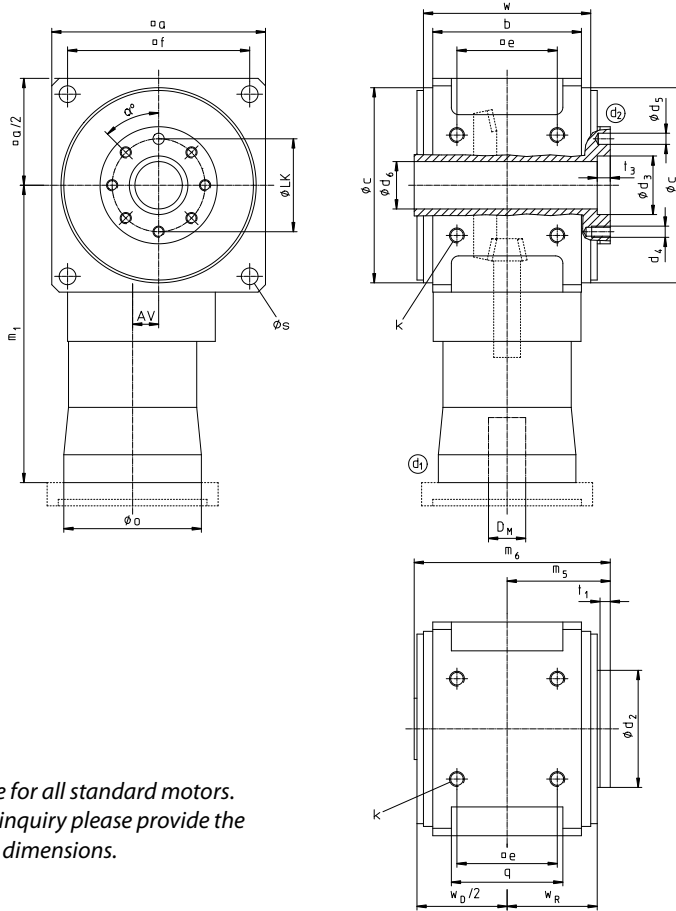

Suitable for all standard motors.
In your inquiry please provide the mating dimensions.

dimensions [mm]

gearbox size	a	b	Ø _{c_{g6}}	D _M	e	f	k depth = 1.5 · k	m ₁	Ø _o	q	Ø _s	w	w _D	w _R	AV
HYP FS2 RF HW 90	90	60	89	8-16	44	78	M6	127.5	59	44	7	79	87	43.5	9
HYP FS2 RF HW 115	115	80	105	8-24	54	98	M8	160	74	60	9	90	97	48.5	14
HYP FS2 RF HW 140	140	100	125	11-28	66	118	M10	177	93	78	11	109	116	58	18
HYP FS2 RF HW 170	170	120	150	14-32	80	144	M12	214	115	94	13.5	128	136	70.5	23
HYP FS2 RF HW 192	192	138	173	14-32	95	164	M12	238.5	115	110	13.5	151	158	79	27
HYP FS2 RF HW 215	215	146	195	19-42	104	182	M16	264.5	136	116	17.5	158	166	83	32
HYP FS2 RF HW 240	240	166	225	19-55	120	206	M16	343	160	134	17.5	178	186	93	38
HYP FS2 RF HW 260	260	196	245	19-55	140	224	M16	348	160	162	17.5	208	216	109.5	42

performance data HYP FS2 RF HW

gearbox size	ratio i	rated torque M _{2nenn} [Nm] 200 min ⁻¹	rated torque M _{2nenn} [Nm] 1500 min ⁻¹	rated torque M _{2nenn} [Nm] 3000 min ⁻¹	max. torque M _{2max} [Nm]	inertia J [10 ⁻⁵ kgm ²]
HYP FS2 RF HW 90	5:1	50	39	31	75	5.3
HYP FS2 RF HW 115	5:1	75	75	66	98	13.7
HYP FS2 RF HW 140	5:1	146	146	115	205	38.8
HYP FS2 RF HW 170	5:1	290	206	164	406	89.8
HYP FS2 RF HW 192	5:1	325	325	289	487	140
HYP FS2 RF HW 215	5:1	726	519	391	963	361.6
HYP FS2 RF HW 240	5:1	1100	661	519	1543	1054.9
HYP FS2 RF HW 260	5:1	1510	859	682	2118	1450.6
HYP FS2 RF HW 90	8:1	49	39	31	61	3.8
HYP FS2 RF HW 115	8:1	85	80	64	120	10
HYP FS2 RF HW 140	8:1	160	136	108	220	29.2
HYP FS2 RF HW 170	8:1	292	201	160	411	66.1
HYP FS2 RF HW 192	8:1	422	313	254	592	94.9
HYP FS2 RF HW 215	8:1	677	464	343	950	255.7
HYP FS2 RF HW 240	8:1	1020	593	448	1445	874.4
HYP FS2 RF HW 260	8:1	1350	753	557	2113	1060.8
HYP FS2 RF HW 90	10:1	36	36	34	63	3.4
HYP FS2 RF HW 115	10:1	75	75	63	104	9.2
HYP FS2 RF HW 140	10:1	147	125	99	206	26.7
HYP FS2 RF HW 170	10:1	245	189	150	344	60.4
HYP FS2 RF HW 192	10:1	355	306	247	539	85.5
HYP FS2 RF HW 215	10:1	612	437	323	859	233.9
HYP FS2 RF HW 240	10:1	908	582	456	1433	832.9
HYP FS2 RF HW 260	10:1	1330	702	520	1867	973.6
HYP FS2 RF HW 115	12:1	67	67	62	94	8.7
HYP FS2 RF HW 140	12:1	116	116	99	163	25.3
HYP FS2 RF HW 170	12:1	211	196	156	296	57.7
HYP FS2 RF HW 192	12:1	322	307	241	452	78.5
HYP FS2 RF HW 215	12:1	504	462	373	706	222
HYP FS2 RF HW 240	12:1	783	595	439	1098	810.5
HYP FS2 RF HW 260	12:1	1063	741	549	1491	924.4
HYP FS2 RF HW 140	15:1	107	107	102	146	24.4
HYP FS2 RF HW 170	15:1	177	177	159	249	55.5
HYP FS2 RF HW 192	15:1	294	294	232	417	73.4
HYP FS2 RF HW 215	15:1	517	376	279	726	211.8
HYP FS2 RF HW 240	15:1	711	561	415	997	792.2
HYP FS2 RF HW 260	15:1	1032	681	504	1447	885.8

Ø LK	Ø d _{2h8}	Ø d _{3H7}	d ₄	number of tapped holes (d4)	Ø d _{5H7} locating pin	Ø d ₆	m ₅	m ₆	t ₁	t ₃	α	gearbox size
40	50	25	M6	7	6	20.5	50.5	95.5	6	8	45°	HYP FS2 RF HW 90
50	63	31.5	M6	7	6	25.5	55.5	105.5	6	7	45°	HYP FS2 RF HW 115
63	80	40	M6	7	6	30.5	65	125	6	7	45°	HYP FS2 RF HW 140
80	100	50	M8	11	8	40.5	80.5	150.5	9	8.5	30°	HYP FS2 RF HW 170
80	100	50	M8	11	8	48.5	96.5	177.5	16	8.5	30°	HYP FS2 RF HW 192
100	125	63	M8	11	8	55.5	100.5	185.5	16	8.5	30°	HYP FS2 RF HW 215
100	125	63	M8	11	8	60.5	115	210	20	8.5	30°	HYP FS2 RF HW 240
125	160	80	M10	11	10	70.5	132.5	242.5	20	8.5	30°	HYP FS2 RF HW 260

Technical Data

permissible radial load

permissible radial load at shafts d_2			
gearbox size	i = $n_1:n_2$ ratio i = $n_1:n_2$	radial force	
		F_{R_R} [N]	F_{R_L} [N]
HYP FS2 90	5:1 to 8:1	1850	1950
HYP FS2 90	10:1	2250	2250
HYP FS2 115	5:1 to 8:1	2550	2650
HYP FS2 115	10:1 to 12:1	3100	3150
HYP FS2 140	5:1 to 8:1	3400	3600
HYP FS2 140	10:1 to 15:1	4550	4600
HYP FS2 170	5:1 to 8:1	6300	6600
HYP FS2 170	10:1 to 15:1	8250	8350
HYP FS2 192	5:1 to 8:1	7000	7150
HYP FS2 192	10:1 to 15:1	9250	9100
HYP FS2 215	5:1 to 8:1	6200	6700
HYP FS2 215	10:1 to 15:1	8300	8300
HYP FS2 240	5:1 to 8:1	9400	10100
HYP FS2 240	10:1 to 15:1	12400	12600
HYP FS2 260	5:1 to 8:1	11500	12300
HYP FS2 260	10:1 to 15:1	15100	15400

The values are applicable for 50% of the permitted torque at an input speed $n_1 = 1500 \text{ min}^{-1}$.

Radial loads for different conditions on request.

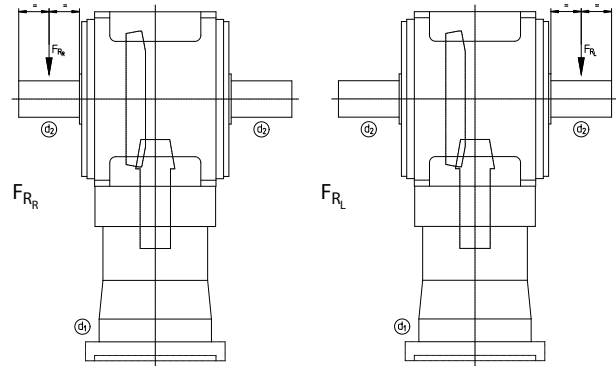

permissible tilting moment

Permissible tilting moment HYP FS2 RF and HYP FS2 RF HW		
gearbox size	ratio i = $n_1:n_2$	M_K^* [Nm]
HYP FS2 RF 90	5:1 to 8:1	170
HYP FS2 RF 90	10:1	200
HYP FS2 RF 115	5:1 to 8:1	260
HYP FS2 RF 115	10:1 to 12:1	310
HYP FS2 RF 140	5:1 to 8:1	400
HYP FS2 RF 140	10:1 bis / to 15:1	550
HYP FS2 RF 170	5:1 bis / to 8:1	950
HYP FS2 RF 170	10:1 to 15:1	1200
HYP FS2 RF 192	5:1 to 8:1	1250
HYP FS2 RF 192	10:1 to 15:1	1550
HYP FS2 RF 215	5:1 to 8:1	1200
HYP FS2 RF 215	10:1 to 15:1	1500
HYP FS2 RF 240	5:1 to 8:1	2000
HYP FS2 RF 240	10:1 to 15:1	2600
HYP FS2 RF 260	5:1 to 8:1	2900
HYP FS2 RF 260	10:1 to 15:1	3700

distance L	
gearbox size	[mm]
HYP FS2 RF 90	77.5
HYP FS2 RF 115	84.5
HYP FS2 RF 140	102
HYP FS2 RF 170	125
HYP FS2 RF 192	152.5
HYP FS2 RF 215	159
HYP FS2 RF 240	176
HYP FS2 RF 260	207.5

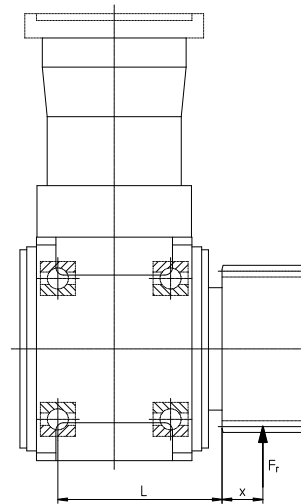

calculation of the tilting torque M_K

$$M_K = \frac{F_R \cdot (L+x)}{1000}$$

M_K [Nm]
 F_R [N]
 $L; x$ [mm]

* the values are applicable for 50% of the permitted torque at an input speed $n_1=1500 \text{ min}^{-1}$

mounting position - please supply with your order.

mounting position standard
(all shafts horizontal)

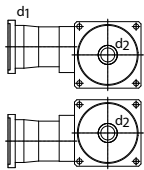

mounting position S515 d1
(d_1 vertical up)

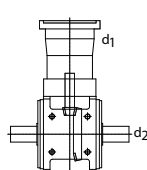

mounting position S515 d2L
(d_2 vertical, ring gear at the bottom)

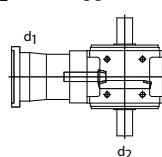

mounting position S515 d2R
(d_2 vertical, ring gear at the top)

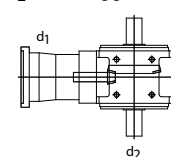

Oil Quantities

Units are typically lubricated for life.

lubricant quantities	
gearbox size	oil [Ltr.]
HYP FS2 90	0.08
HYP FS2 115	0.15
HYP FS2 140	0.3
HYP FS2 170	0.45
HYP FS2 192	0.65
HYP FS2 215	1
HYP FS2 240	1.4
HYP FS2 260	1.9

Listed quantities are approximate values.
Castrol Optigear Synthetic R0150 or equivalent.

Motor Mounting Instructions

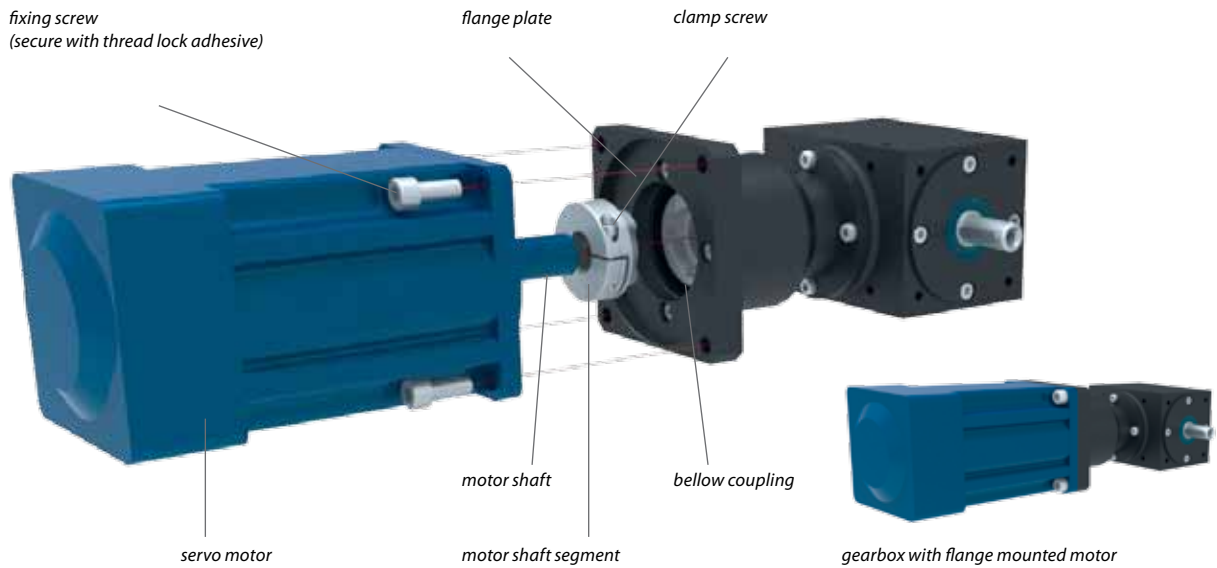

gearbox size	preload dimension H [mm]	tightening torque at the motor shaft [Nm]	screw size
HYP FS2 90	0.3-0.5	5	M 4
HYP FS2 115	0.5-1.0	4.1	M 4
HYP FS2 140	0.5-1.0	14	M 6
HYP FS2 170	0.5-1.5	35	M 8
HYP FS2 192	0.5-1.5	35	M 8
HYP FS2 215	0.5-1.5	69	M 10
HYP FS2 240	0.5-1.5	120	M 12
HYP FS2 260	0.5-1.5	120	M 12

Motor Assembly Instructions

assembly of the two part coupling

Before assembly the position of the coupling must be set so that after assembly the preload H (see table) is reached.

The bellows with tapered hub (Pos1) are already mounted to the gearbox.

Insert the tapered element into the hub without backlash and axial load.

Measure dimension X (see picture) from the motor mounting face of the gearbox flange and the face of the tapered segment (Pos. 2) and note this dimension.

The tapered segment (item 2) is then removed, slid onto the motor shaft and the installation dimension (X + H) set.

Secure the tapered segment by tightening the clamping screw using a torque wrench, to the tightening torque specified in the table.

Slide the motor on to the gearbox. It must be ensured that the tapered sections of both parts of the coupling are clean. Then screw the flanges of the gearbox and motor securely together.

NOTE!

To ensure backlash free torque transmission, the preload H, which is fixed before assembly, must be strictly observed. The maximum permissible misalignment values for the coupling are not reduced by preloading.

Assembly of the two part metal bellows coupling

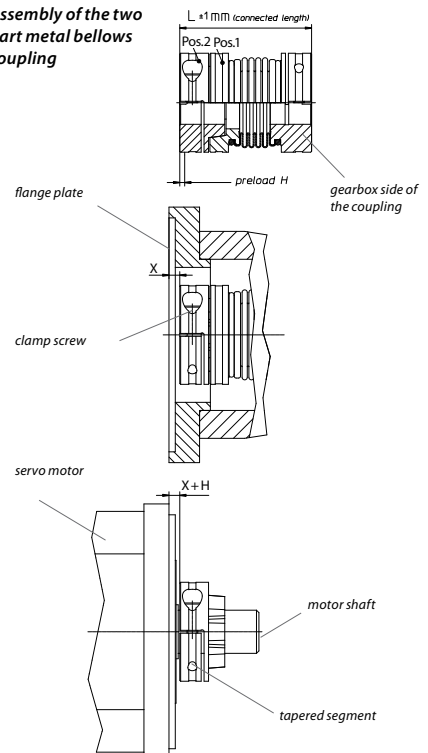

Other Servo Gearhead Products

ServoFoxx



Precision Planetary
& Bevel Gearheads

Planetdrive



Economy Inline
Planetary Gearheads

Dynabox



Right Angle Precision &
Economy Gearheads

WATT Drive



Helical Gearing
Servo Gearheads

The DieQua Advantage

DieQua Corporation has been a manufacturer and supplier of precision motion control components for over 30 years. We offer the widest range of servo gearhead and speed reducing solutions available from a single source. Featuring right angle and inline designs with multiple backlash precision levels, the largest number of ratios, and several mounting and output options, we have the drive that meets your needs.

Engineering Support

DieQua Corporation has several decades of combined experience specifying power transmission and motion control components. This assures the proper selection of components and systems for your unique requirements.



Assembly

DieQua Corporation has a team of factory trained technicians that assemble the majority of the drives we provide. This allows prompt delivery of your production requirements or service repairs.



Warehousing

DieQua Corporation maintains an extensive inventory of common speed reducer and motor components for quick delivery of small orders, prototypes and spare parts.



Manufacturing

DieQua Corporation's manufacturing capabilities allow production of many of the components used in the drives we provide. Mounting components and design modifications are also available from our full service machine shop.



DIEQUA
Corporation

Motion Components and Engineering Services

180 Covington Drive, Bloomingdale, Illinois USA 60108-3105

Phone: 630-980-1133 Fax: 630-980-1232

Email: info@diequa.com

Web: www.diequa.com

Local Representative: