

quick and easy
 → copy
 → select
 → fax / e-mail
 or PDF at www.zimm.eu

Checklists - Sheet 1 - Parameters

Company: _____ Date: _____
 Address: _____ Phone: _____
 Contact: _____ Fax: _____
 Dept.: _____ E-mail: _____

1. max. lifting force in kN

- per gearbox _____ kN for the entire system _____ kN
 - in tension _____ kN in compression _____ kN
 - Load: static _____ kN dynamic _____ kN

Installation axis

vertical horizontal pivoting

Type of load

smooth impact loads vibration

2. max. lift/travel _____ mm effective working stroke _____ mm

For short stroke applications

(eff. working stroke < gearbox height): regular lubrication stroke practical not practical

3. Lifting speed

type N = 25 mm/s (1.5 m/min) type L = 6.25 mm/s (0.375 m/min) _____ mm/s

4. Duty factor, work cycle, description of cycle

_____ strokes per hour _____ strokes per day Hours per day 8 16 24

i For high duty factors or long strokes, please provide an exact detailed description on page 141, 4a

5. Type S "Translating screw" R "Rotating screw" | Z screw jack GSZ screw jack

6. Motor Three-phase AC motor With brake Manual release _____

7. Operating conditions: Dry Humid Dust Chipping _____ Guided movement No guides (no dyn. lateral forces)

Ambient temperature: min. _____ °C max. _____ °C (when <10°C and >40°C)

i If possible please provide an exact description or sketch on page 141, 7a

8. Standard layouts no.: _____ Size: MA1 _____ MA2 _____ MA3 _____ MA4 _____ MA5 _____

see standard layouts, checklist sheets 5 and 6 (for multi-jack systems)

9. Quantity Required: _____ Series: _____

10. Schedule Quotation: _____ Delivery: _____

Checklists - Sheet 3 - List of components S

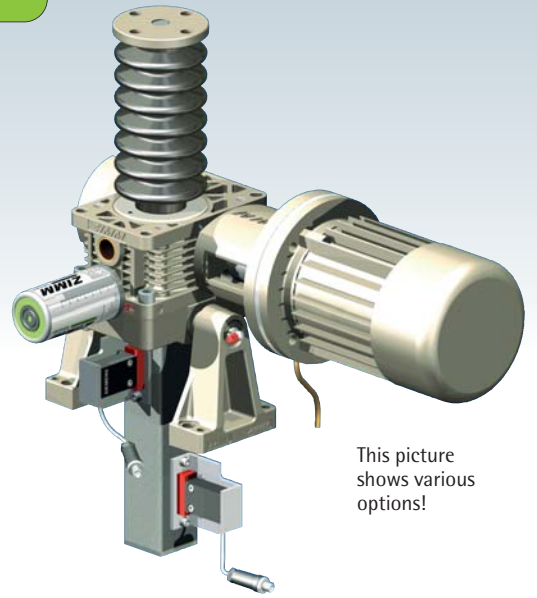

This picture shows various options!

- Type:
- SN (Translating screw, normal)
 - SL (Translating screw, low speed)
- Variant:
- Tr screw
 - SIFA safety nut
 - with SIFA monitoring
- KGT ball screw

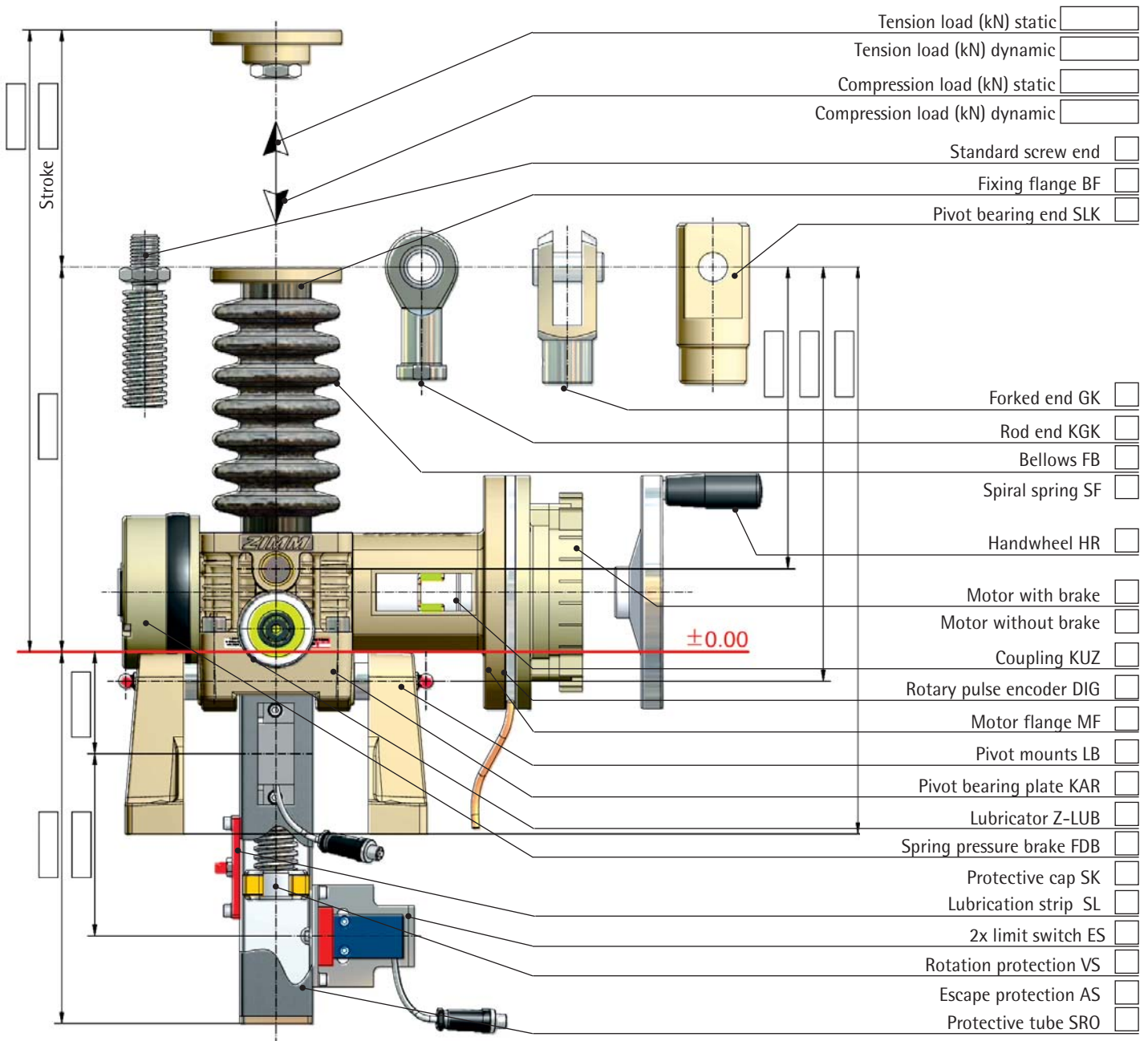

Checklists - Sheet 4 - List of components R

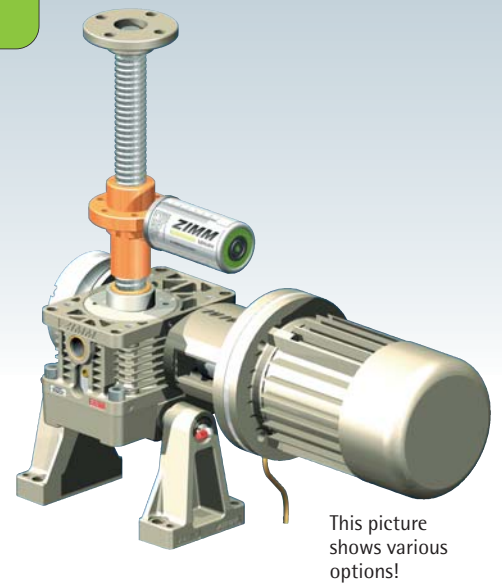

Type:

- RN (Rotating screw, normal)
- RL (Rotating screw, low speed)

Variant:

- Tr screw
- SIFA safety nut
- with SIFA monitoring

- KGT ball screw

Stroke

±0.00

- Tension load (kN) static
- Tension load (kN) dynamic
- Compression load (kN) static
- Compression load (kN) dynamic
- Opposed bearing plate GLP
- Bellows FB
- Spiral spring cover SF
- Lubricator Z-LUB
- Cardan adapter DMA
- Duplex nut DM
- Tr flange nut FM
- KGT flange nut KGT-F
- Self-aligning nut PM
- Greaseless nut FFDM
- Driving flange TRMFL
- Safety nut SIFA
- Wear monitoring SIFA Control
- Handwheel HR
- Motor with brake
- Motor without brake
- Rotary pulse encoder DIG
- Motor flange MF
- Coupling KUZ
- Pivot mounts LB
- Pivot bearing plate KAR
- Spring pressure brake FDB
- Protective cap SK

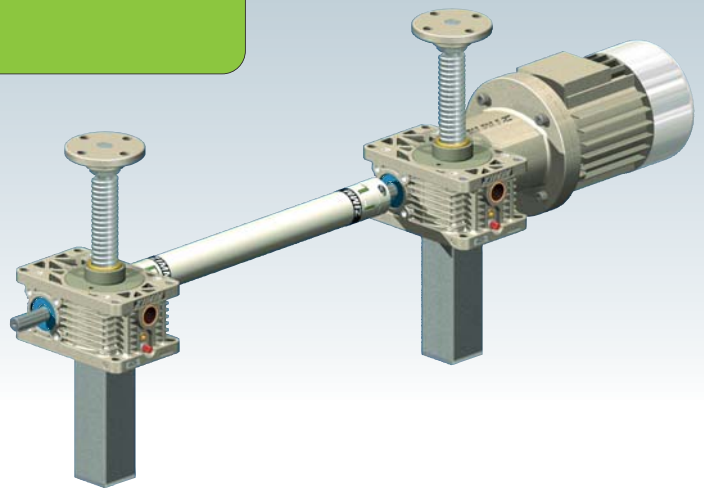

Checklist - Sheet 5 - System layouts

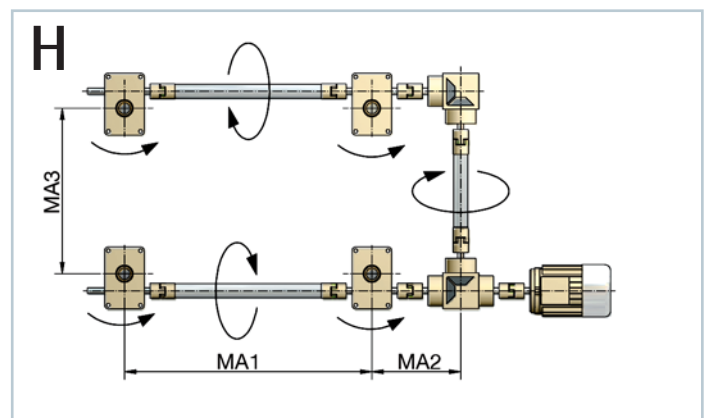
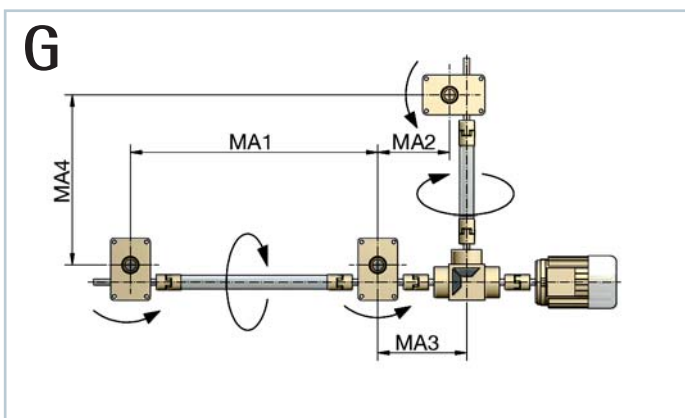
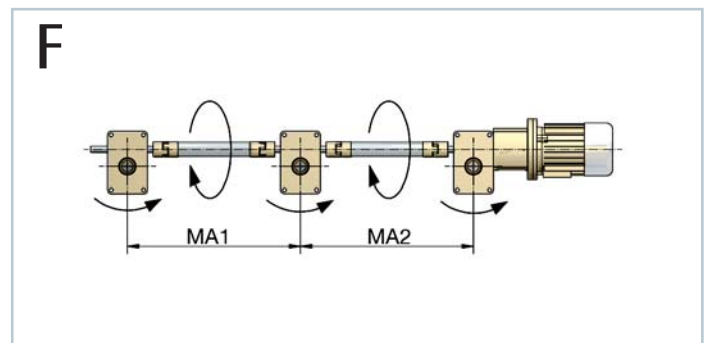
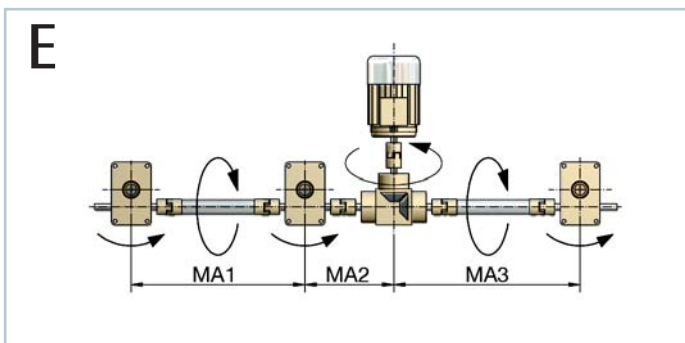
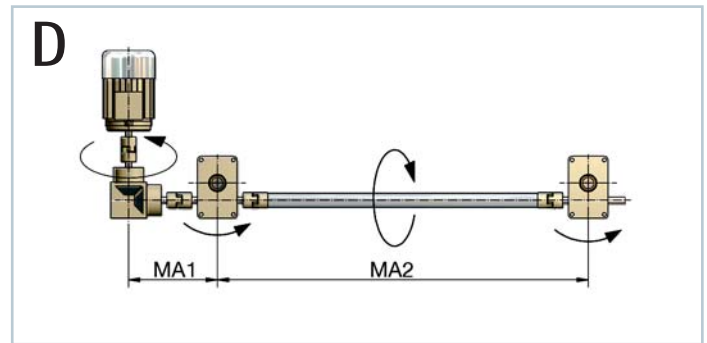
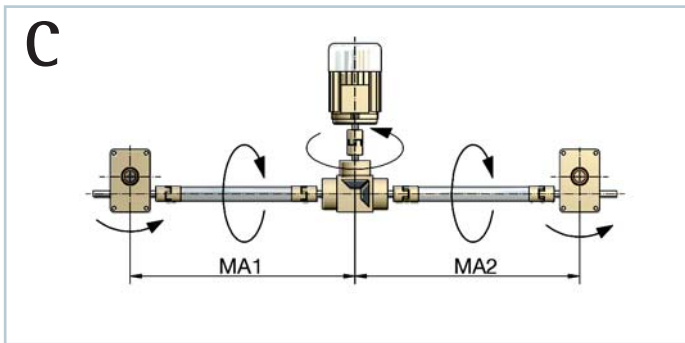
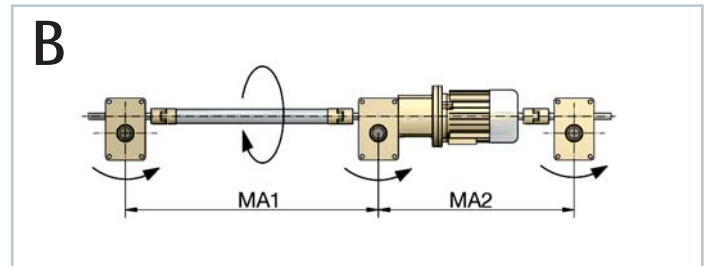
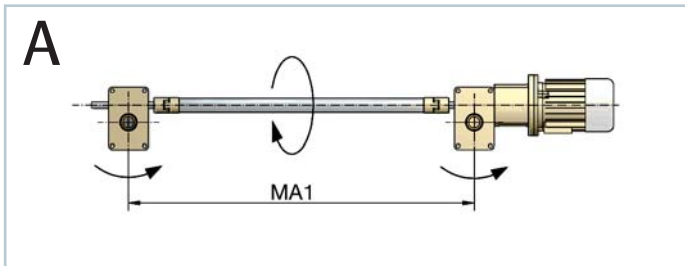

The most common layouts are shown. If your design is different, be sure to check the direction of rotation!

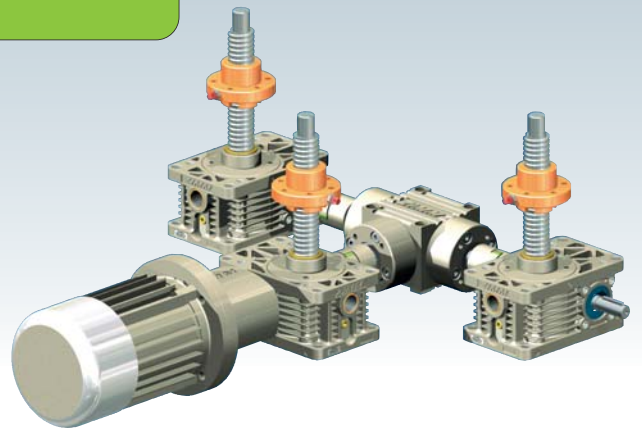

Checklist - Sheet 6 - System layouts

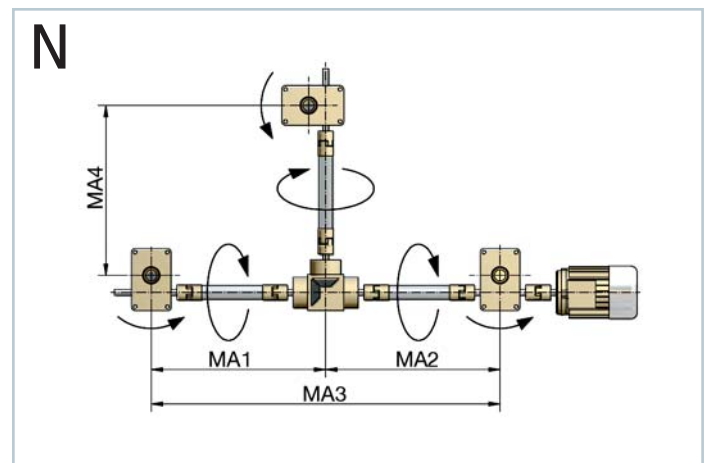
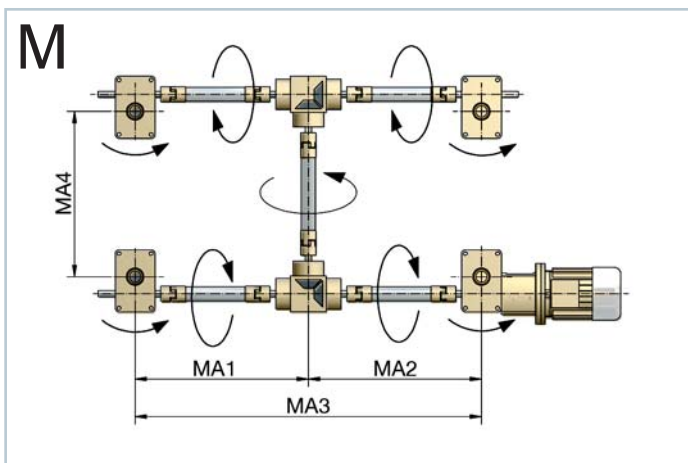
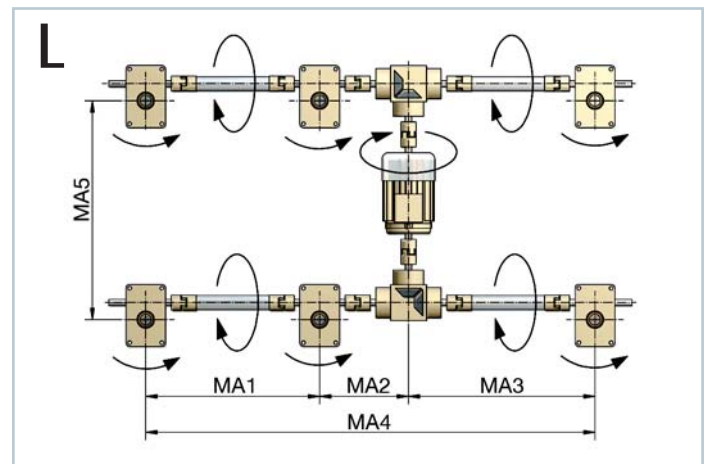
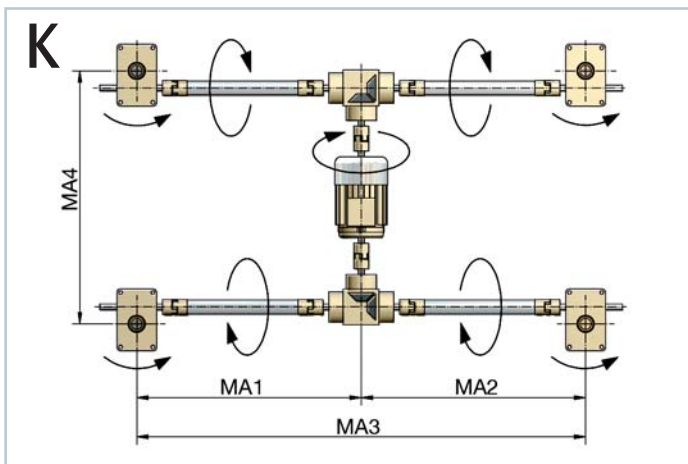
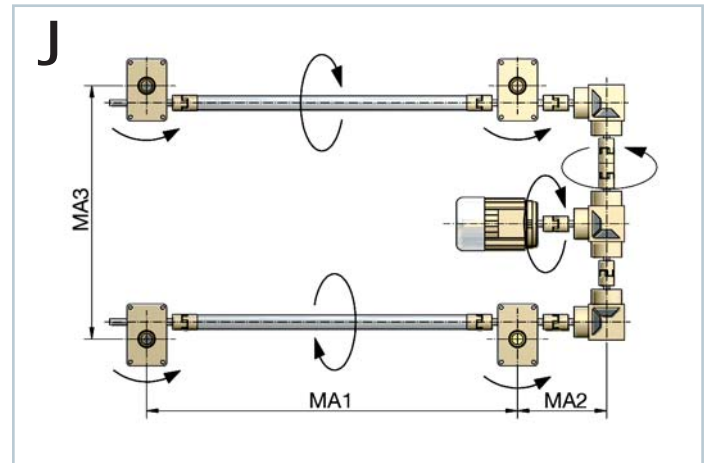
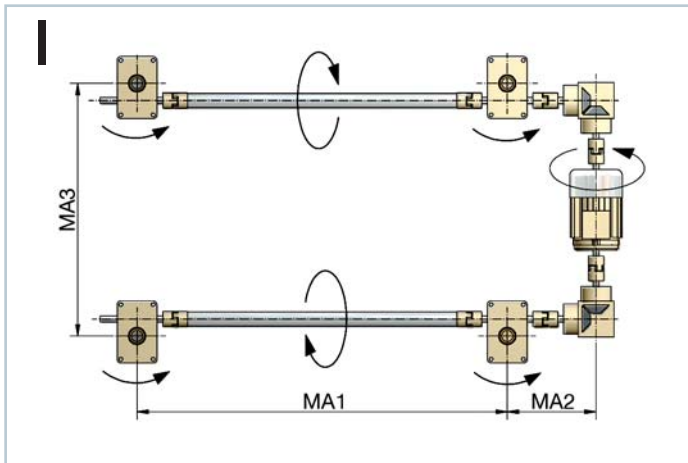

The most common layouts are shown. If your design is different, be sure to check the direction of rotation!